



WALKER
INDUSTRIAL SYSTEMS



Walker Industrial Blower Fans

Our industrial range of fans and ventilation equipment

Walker Industrial Systems are the industrial fan and blower portfolio of the GJ Walker Group.

Servicing customers Australia-wide, we provide robust ventilation solutions for industrial environments. With the ability to customise products to suit individual project requirements, we manufacture a variety of options for different applications.

With performance and reliability at the forefront of design, our fans and blowers are also backed by an experienced team. Our expertise spans a wide range of commercial, HVAC, and industrial environments, and we provide exceptional service, delivery, and performance to the market that is synonymous with the GJ Walker name.



Pharmaceutical



Mining



Paper & Pulp



Manufacturing

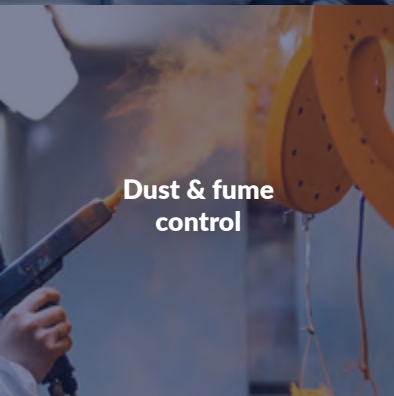

Dust & fume control



Food processing



Water Treatment

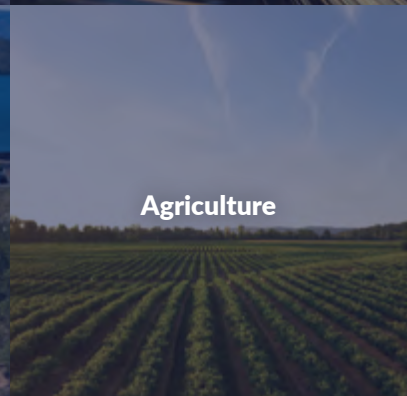

Agriculture

DWDI Fans

Walker Industrial Systems double width double inlet fans are made for performance and reliability in a multitude of HVAC installations plus many industrial supply or exhaust systems. They can be manufactured with backward inclined, backward curved or airfoil impellers.



Sizes
350mm to 2400mm



Power range
0.75kw to 300kW



Construction
Galvanised steel, mild steel, stainless steel



Air volumes
exceeding 150,000 l/s

Applications



Car park supply & exhaust



AHU's



Shaft ventilation



Supply air systems



Mining

SWSI Fans

Single Width Single Inlet fans by Walker Industrial Systems are made for high efficiency, low sound levels and reliability. These high performing fans require low maintenance and can be manufactured with backward inclined, backward curved, radial or airfoil impellers.

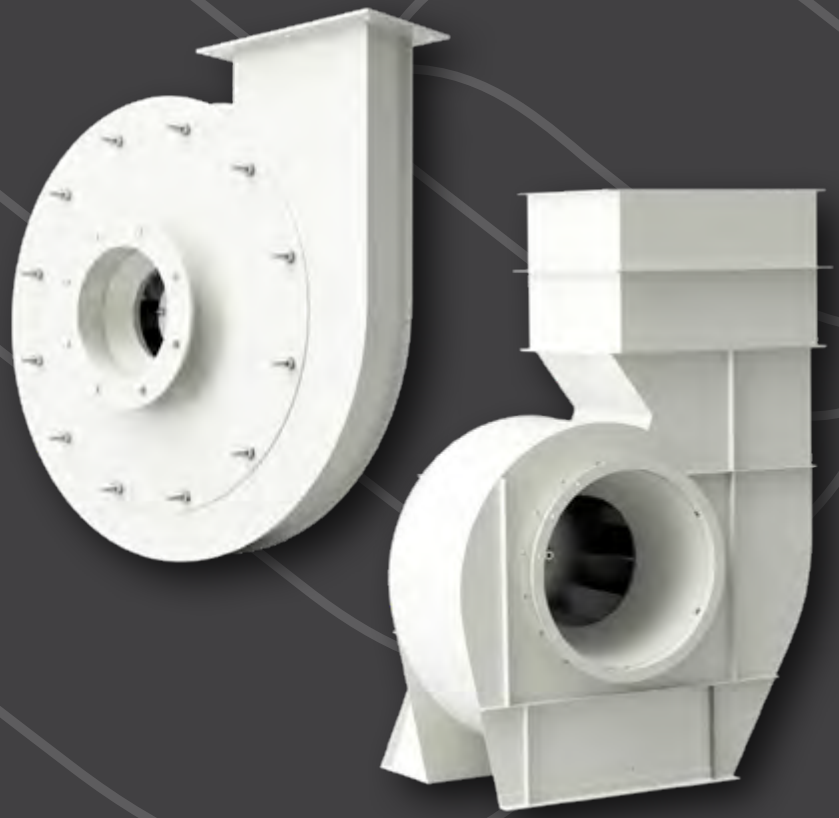

Sizes
310mm to 2400mm



Power range
0.75kw to 300kW



Construction
Galvanised steel, mild steel, stainless steel



Pressure
10kPa



Modular solutions
to 37kW



Foot or flange mount



Standard or increased safety solutions



Design temperatures
up to 450°C

Applications



Kitchen exhaust



Toilet exhaust



Dust & Fume



Spray booths



Mining



Agriculture



Ovens & Furnaces



Water Treatment



Industrial Process



Food Production



Manufacturing



Paper & Pulp

Axial fans

Made for ventilation, HVAC and industrial applications, Walker Industrial Systems axial fans are recommended for tough environments where customised solutions are necessary to support critical production, processing or air movement requirements.

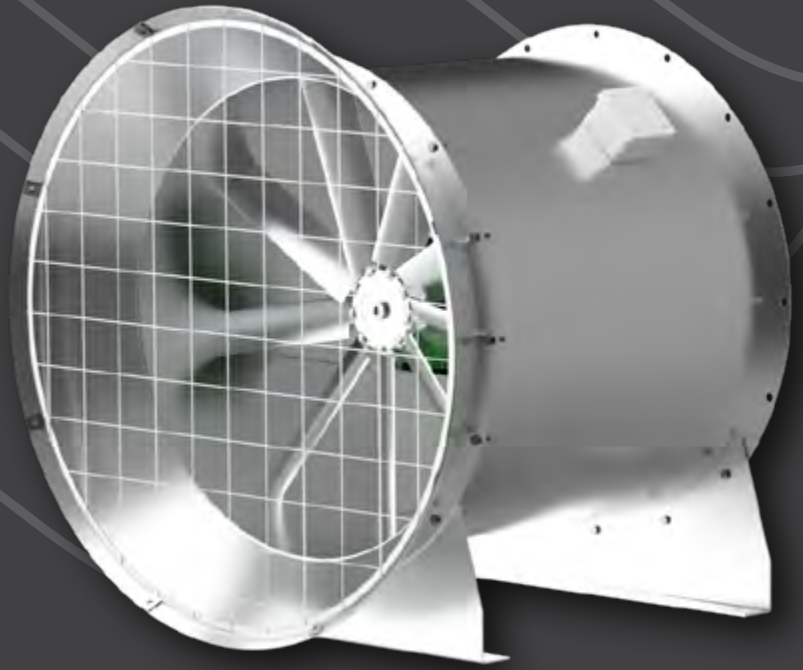

Sizes
315mm to 1800mm



Power range
0.37kW to 110kW



Construction from
galvanised steel, mild
steel, stainless steel



Air volumes
exceeding 80,000 l/s

Options



Bifurcated



Belt driven



Silencers

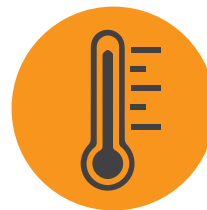

**High
temperature**



**Aluminium, PPG
or anti-static
impellers**



**Victorian and
Tasmanian office**

6-10 Souffi Place
Dandenong South VIC 3175

Ph: +61 3 9706 6313

**Queensland
office**

Unit 4, 53-57 Link Drive
Yatala Qld 4207

Ph: +61 7 3804 6833

**New South Wales and Australian
Capital Territory office**

23a/70 Holbeche Road
Arndell Park NSW 2148

Ph: +61 2 8968 9347

**Western Australian, South Australian
and Northern Territory office**

Integrity House, 67 Howe Street
Osborne Park WA 6017

Ph: +61 8 9202 6821

  www.gjwalker.com.au | info@gjwalker.com.au